

# INTERCEPTORS

## 800 Series

TAG \_\_\_\_\_  
 \_\_\_\_\_

### Polypropylene Grease Interceptors, Series 811

**Product Description:** Recommended for removing, then retaining fat, oil, and grease from wastewater in kitchen and restaurant areas where food is prepared. The 811 series is injection molded in engineered thermoplastics; it will not corrode, chip or peel; even under the most severe conditions. The tank is injection molded in one-piece eliminating seams that could be potential areas of leakage. Removable baffles combined with a smooth interior surface make cleaning quick and easy. This polypropylene GI consists of a reinforced cover with securing latches, removable inlet and outlet baffles, a diffuser baffle, a one-piece tank, a no-hub inlet and outlet, and a PVC flow control assembly with air intake tee and integral cleanout.

#### Features and Benefits:

- Injection molded in Polypropylene, will not chip, rust or corrode
- Light weight facilitates transportation, handling, and installation
- Can support 440 pounds of pedestrian and light duty traffic load and can withstand temperatures of 220° F
- Uses a neoprene gasket and eight quick connection latches to provide a positive airtight seal and easy access for cleaning
- Sizing: 15, 20, 25, 35 and 50 G.P.M. flow rate
- PDI-G101 and IAPMO Listed, File No. 4022

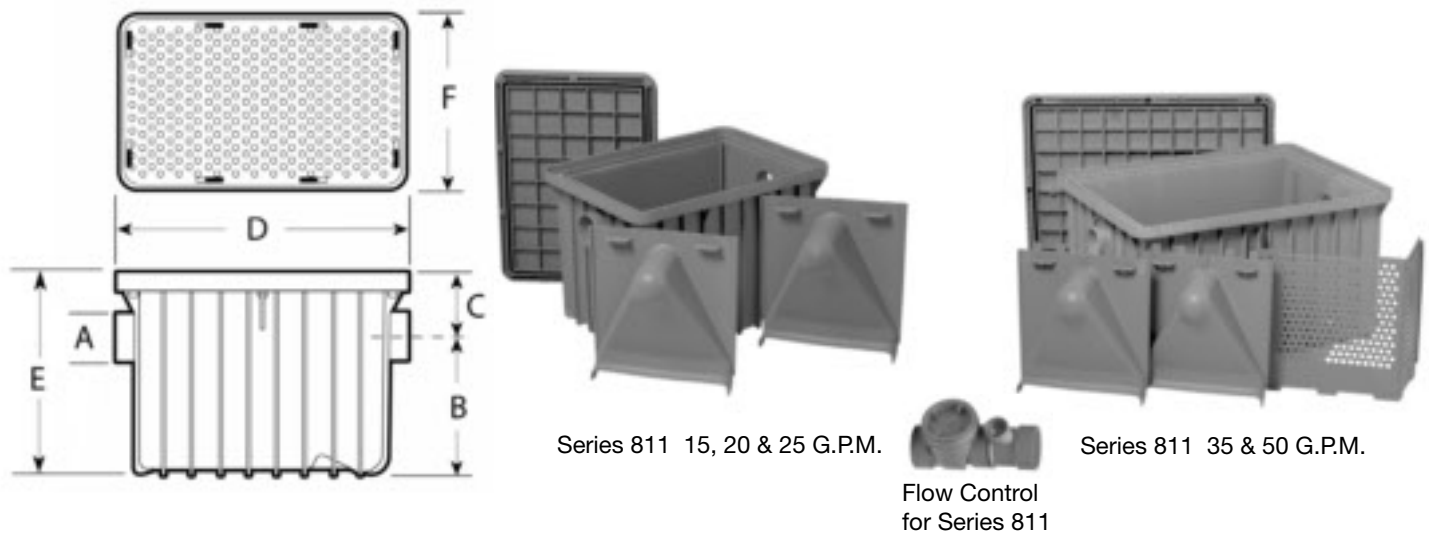

Figure Number	Material Type	GPM Flow Rate	Grease Cap LBS	A	B	C	D (Length)	E (Height)	F (Width)	Connection Type
<input type="checkbox"/> 811-Y03-15	Polypropylene	15	30	3"	12 1/8"	4 3/16"	23 5/8"	16 5/16"	17 1/2"	No-Hub
<input type="checkbox"/> 811-Y03-20	Polypropylene	20	40	3"	12 1/8"	4 3/16"	23 5/8"	16 5/16"	17 1/2"	No-Hub
<input type="checkbox"/> 811-Y03-25	Polypropylene	25	50	3"	12 1/8"	4 3/16"	23 5/8"	16 5/16"	17 1/2"	No-Hub
<input type="checkbox"/> 811-Y03-35	Polypropylene	35	70	3"	12 1/2"	5"	31"	17 1/2"	23 1/2"	No-Hub
<input type="checkbox"/> 811-Y03-50	Polypropylene	50	100	3"	18 1/4"	5"	31"	23 1/4"	23 1/2"	No-Hub

NOTE: Dimensional data is subject to manufacturing tolerances and change without notice.